



KOBE Biennale 2011 “Art in a Container” International Competition Work Proposal 2

Title of work

Idea Sketch : Use any means or media you wish. (Computer graphics are also acceptable.)

※Please do not change size(A4) or direction(horizontal)

Reference number

# KOBE Biennale 2011 "Art in a Container" International Competition Work Proposal 3

Title of work \_\_\_\_\_

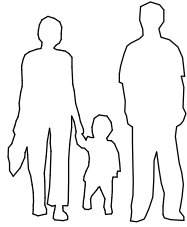

Scale 1:60

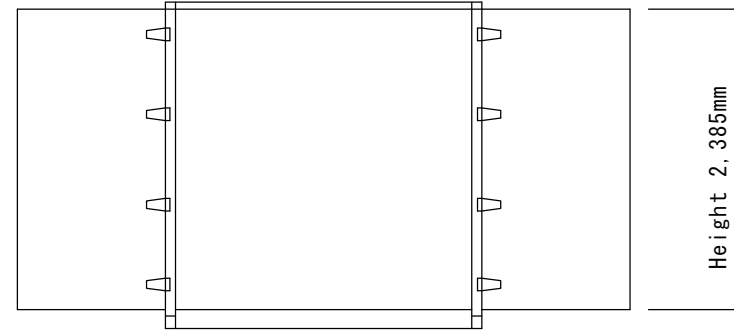

As rain may get in, nothing should be exhibited in the space extending 1,500mm inside the door

Width 2,352mm

FRONT VIEW

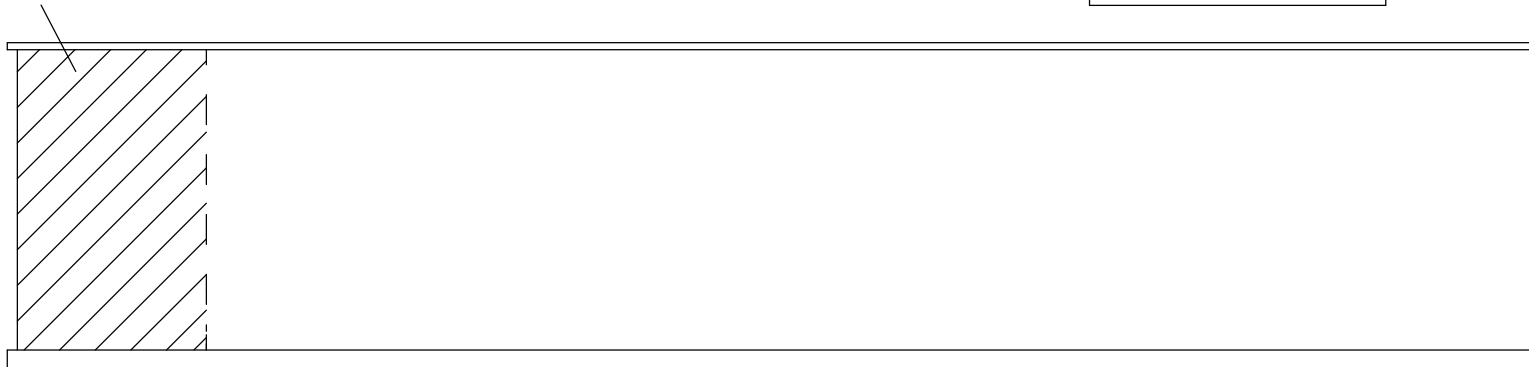

SIDE VIEW

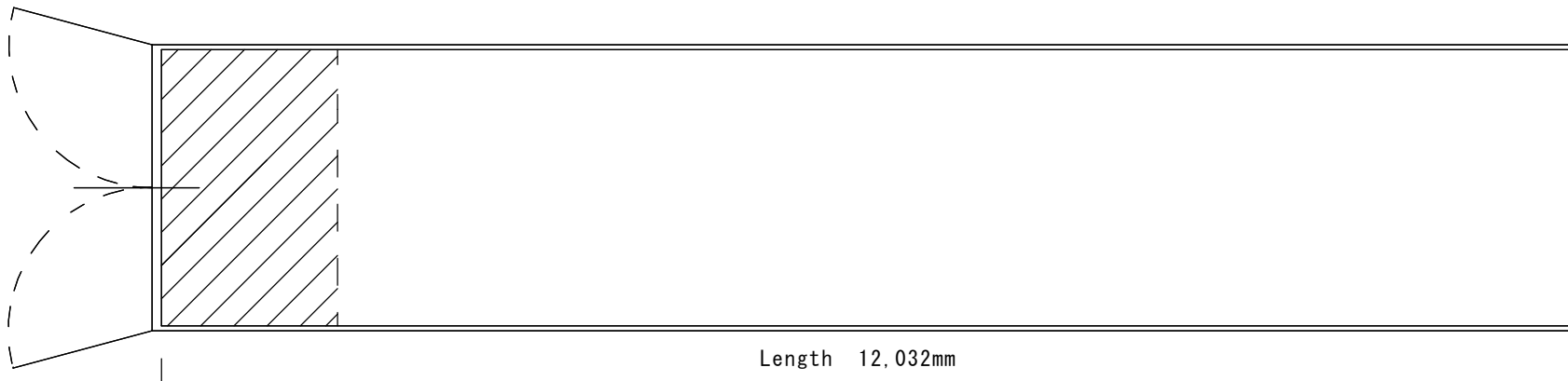

TOP VIEW

Reference number \_\_\_\_\_

KOBE Biennale 2011 “Art in a Container” International Competition

Photo(s) of model of proposed work (optional)

Title of work \_\_\_\_\_

※Attach image to this sheet (multiple images are OK).

※One A4 Sheet, horizontal

Reference number \_\_\_\_\_

KOBE Biennale 2011 “Art in a Container” International Competition Photo(s) of past work (optional)

Title of work \_\_\_\_\_

※Attach image to this sheet (multiple images are OK).

※One A4 Sheet, horizontal

Reference number \_\_\_\_\_